

SecureMag™

Encrypted Intelligent MagStripe Swipe Reader

Full Functionality & Compact Size

SecureMag™ is a 100mm magnetic stripe card reader that offers retailers a complete and reliable security solution. This intelligent reader delivers superior reading performance while encrypting sensitive data that complies with PCI-DSS requirements. The SecureMag™ ensures all data transactions are protected from end to end reducing fraud and data compromises. Data encryption prevents card holder information from being accessed when data is stored or in transit. It also allows customers the flexibility to choose a decryption party right for them. The SecureMag™ supports TDES and AES data encryption using DUKPT key management.

Security Management

Each SecureMag™ card reader is assigned a unique serial number for tracking purposes. Encrypted data output with confirmation data in clear text form is programmable up to the first six digits and the last four digits of the account number. For increased data protection, SecureMag™ has several operational security levels allowing the user to select the security profile needed for the application.

Easy to Use & Install

The uniquely designed flat surface allows for mounting in different orientations using threaded inserts or Velcro®. The cable can exit through the side or bottom which provides flexibility in mounting options.

Features and Benefits

- Reader can function as a standard reader, or can be configured to an encrypted reader
- Each device includes a unique serial number
- Provides clear text confirmation data including card holder's name and a portion of the PAN as part of the masked track data
- Powered through USB port, no external power supply required
- Bi-directional card reading
- Reads encoded data that meets ANSI/ISO/AAMVA standards and most custom formats such as ISO track one format on track two or three
- Reads up to three tracks of card data
- Clear identification of successful card reads with a beeper and tricolored LED indicators
- Supports TDES & AES encryption (TDES is standard)
- DUKPT key management



IDTECH®
Value through Innovation

SecureMag™ Specifications IDRE-33XXXX

Electrical

Power Requirements: +5 VDC +/-10%, 50mV ripple Max.
USB Keyboard, USB HID 5.5mA typical with LED, 8mA peak

Interfaces: USB Keyboard and USB HID

Environmental

Operating Temperature: 0°C to 55°C (32°F to 131°F)
Storage Temperature: -30°C to 65°C (-22°F to 149°F)
Humidity: Maximum 95% non-condensing, dry storage

Reliability

Operating Life: 1,000,000 cycles minimum
Conformance: ISO 7811 1-6
Warranty: Two years, parts and labor

Mechanical

Media Thickness: 0.015 inches (0.381mm) to 0.035 inches (1.12mm)
Media Formats: ISO 7811, AAMVA, and CA DMV
Slot Width: 0.050 inches (1.37mm)
Swipe Speed: 3 to 60 inches per second, bi-directional
Dimensions(L)x(W)x(H): 3.94 inches (100mm) x 1.38 inches (35mm) x 1.18 inches (30mm)
Weight: 7 oz.
Indicators: Tricolored LED, beeper
Cable Length: 6-foot side exit cable (Bottom exit is an option)

Foot Print:

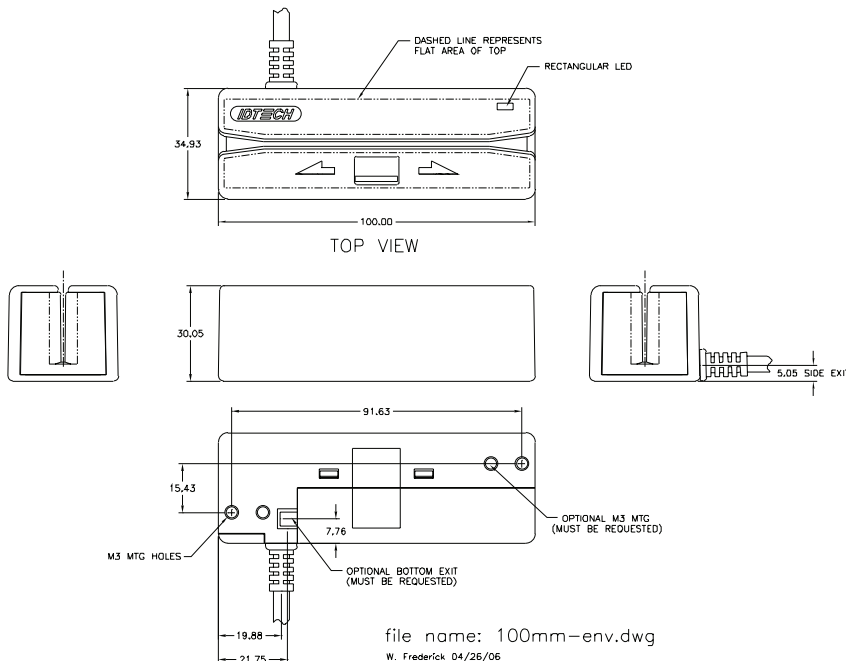

IDTECH®
Value through Innovation

Corporate Headquarters:
10721 Walker Street, Cypress, California 90630
www.idtechproducts.com
(714) 761-6368 sales@idtechproducts.com

International Sales Office
Canada & South America:
+450 465 5261 (Canada) roberttop@idtechproducts.com

European Sales Offices:
+49(0) 8851 6159900 (Germany)
emea@idtechproducts.com

ISO 9001 Certified

Legacy Technology Services

We Rent & Sell All Types Of Barcode Equipment

Call now to talk to an expert

866-271-9891

www.LegacyGlobal.com

Some brands we carry



MOTOROLA

Intermec

DATALOGIC™

Honeywell

EQUINOX
PAYMENTS



About us

- Legacy Technology Services is a leading nationwide provider of mobile computing, barcode, printers and point of sale equipment and services.
- For over a decade, thousands of clients across North America have trusted us to provide equipment from leading manufacturers backed by the services to support them.

Latest Hardware from top manufacturers

- Legacy handles virtually every major manufacturer of mobile computing, barcoding and point of sale equipment.

Expert Repair and Maintenance services

- Legacy is one of the best repair facilities in North America

Discontinued product sourcing

- They don't make it anymore? Our inventory also includes manufacturer close-outs and discontinued equipment to support our clients legacy infrastructure.

Trade-in and Disposal services

- That old equipment laying around your facility may still have some value. Legacy routinely purchases equipment from our clients around the globe.
 - Data destruction
 - Hardware disposal
 - Auditing services

Dedicated client account team

- Dedicated, highly trained account managers are here to answer all your questions and provide top notch service.

Equipment rental services

- Sometimes renting is a better solution, Legacy's huge rental inventory provides the equipment you need for temporary needs and projects.



Legacy, Inc.

160 West Road,
Ellington, CT 06029

Toll Free: 866-271-9891

Fax: 888-522-4684